

Stick

Josep Ll. Xuclà

Proyector LED orientable fabricado en aluminio mecanizado con óptica de 10° o 25° para instalación en falso techo con muelles.

Directional machined aluminum LED spotlight with 10° or 25° optic beam angle for false ceiling installation with springs.



Stick 1110

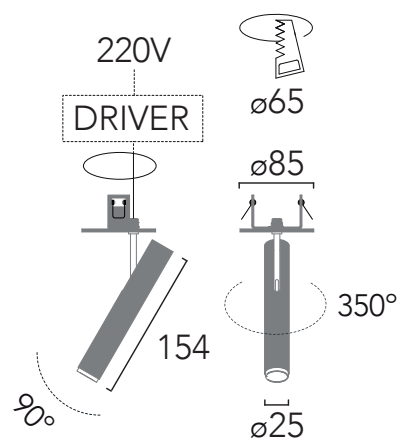

Luz / light

LED 6W - 600 lm - 2700K/3000K - 10°/25°
200/240V 50/60Hz

Driver suministrado / Driver supplied

Acabados / Finishes

Blanco / White
Negro / Black
Champagne
Custom RAL
Bronce / Bronze
Latón satinado / Brushed brass
Grafito satinado / Brushed graphite

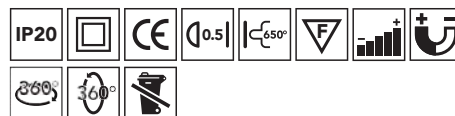

INSOLIT

c/ Cerignola 13, 08022 Barcelona
+34 932 507 640 • insolit@insolitbcn.com • insolitbcn.com

1110

Stick



Proyector LED orientable fabricado en aluminio mecanizado con óptica de 10° o 25° para instalación en falso techo con muelles.

Directional machined aluminum LED spotlight with 10° or 25° optic beam angle for false ceiling installation with springs.

Código / Code	1110
Acabados / Finishes	01 Blanco / White 03 Negro / Black 04 Champagne 00 RAL (Consult)
Luz / Light	27 LED 6W - 600 lm - 2700K 200/240V 50/60Hz 30 LED 6W - 600 lm - 3000K 200/240V 50/60Hz Driver suministrado / Driver supplied
Ángulo de apertura / Beam angle	10 10° 25 25°

Acabados especiales / Special finishes	30 Bronce / Bronze 31 Latón satinado / Brushed brass 33 Grafito satinado / Brushed graphite
---	--

Diseñador / Designer	Josep Ll. Xuclà
Año / Year	2020
Peso / Weight	0,28 kg
Potencia máx. / Max Power	6W
Regulación / Dimmable	TRIAC
Material	Aluminio / Aluminium
Alimentación LED / LED tension	500mA
CRI	90
Dimensiones embalaje / Box Dimensions	38x22x11mm

Instalación / Installation
 En falso techo con muelles. Agujero de diámetro 65 mm para la instalación. False ceiling installation with springs. 65 mm diameter hole for installation.

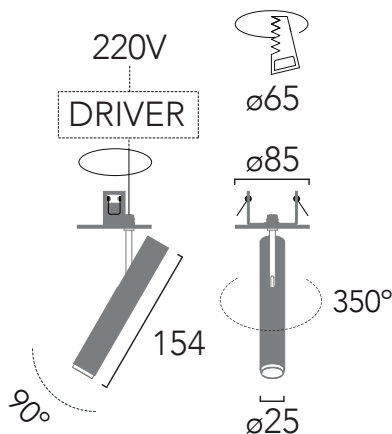

Fabricado según normativa EN60598-1 y regulaciones pertinentes. / Manufactured according EN60598-1 normative and relevant regulations.

Stick

Josep Ll. Xuclà

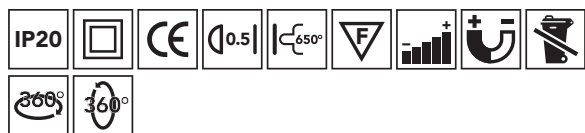
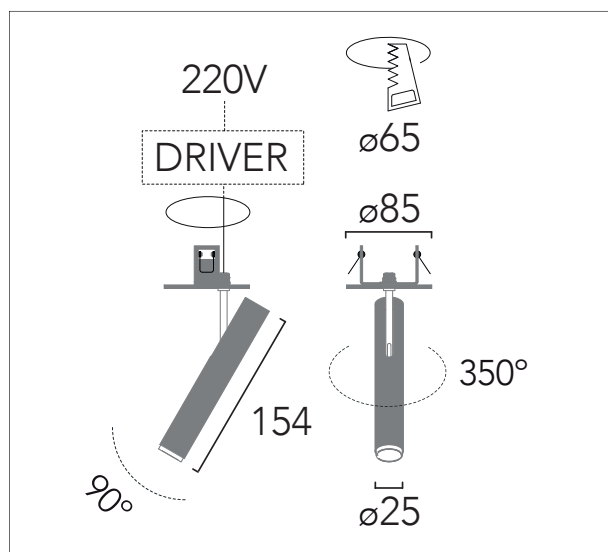

INSOLIT

c/ Cerignola, 13
08022 Barcelona
+34 932 507 640
insolit@insolitbcn.com
insolitbcn.com

Stick

Josep Ll. Xuclà



1110XX01

Instrucciones de montaje
Installation instructions

INSOLIT

Instalación y conexión / Installation and Connection

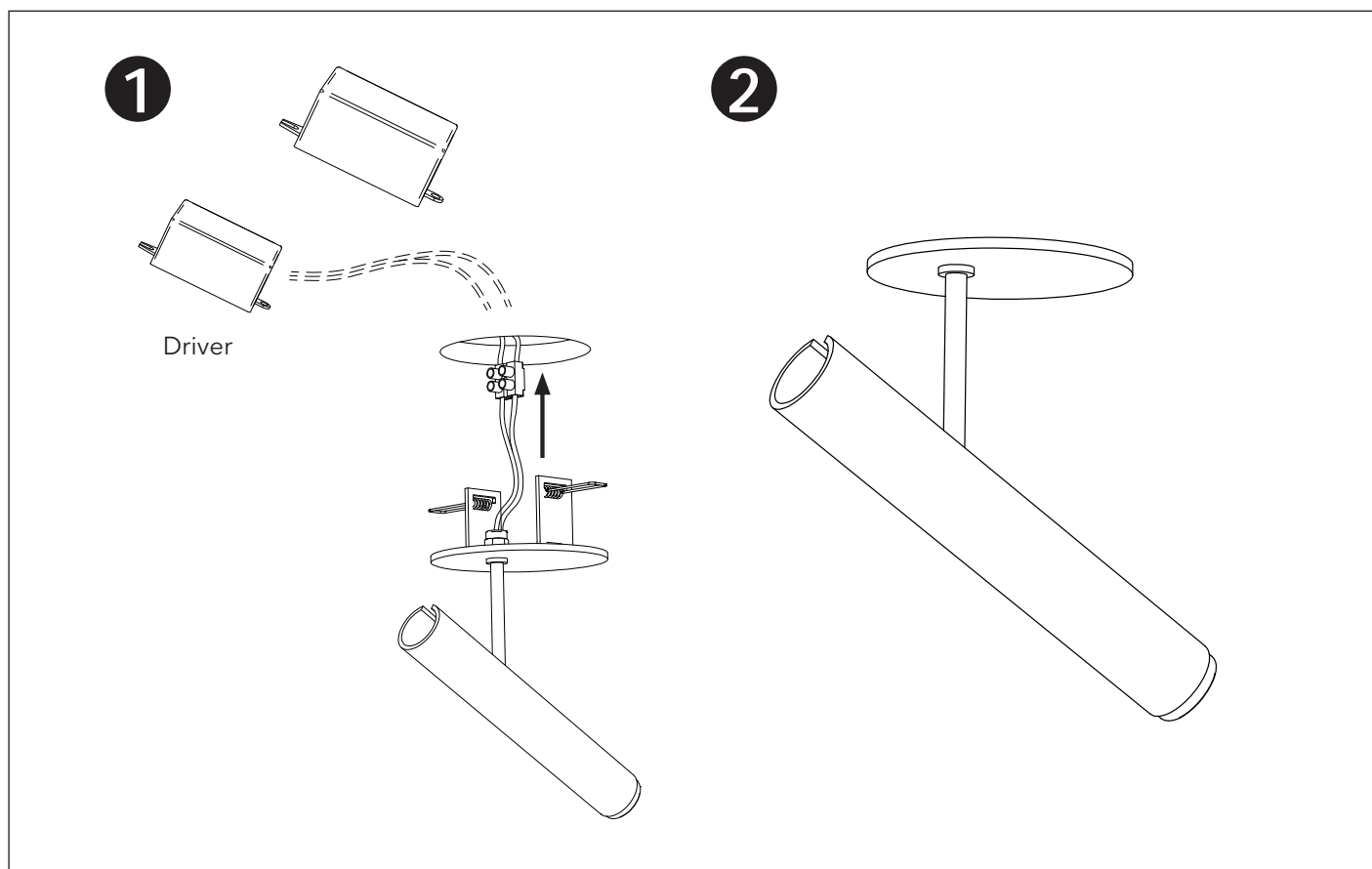

Stick Box

Josep Ll. Xuclà

Proyector LED orientable fabricado en aluminio mecanizado con óptica de 10° o 25° para instalación de empotrado directo con cajetín eléctrico.

Directional machined aluminum LED spotlight with 10° or 25° optic beam angle for built-in installation with an electric box.



Stick Box 1111

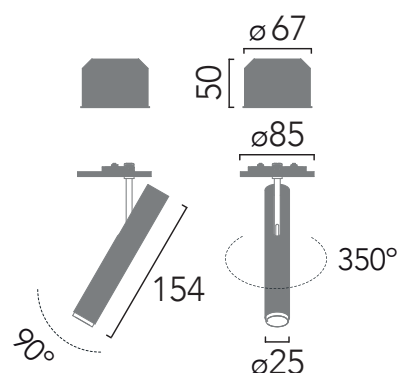

Luz / light

LED 6W - 600 lm - 2700K/3000K - 10°/25°
200/240V 50/60Hz

Driver suministrado
Driver supplied

Cajetín eléctrico suministrado
Electrical box supplied

Acabados / Finishes

Blanco / *White*
Negro / *Black*
Champagne
Custom RAL
Bronce / *Bronze*
Latón satinado / *Brushed brass*
Grafito satinado / *Brushed graphite*

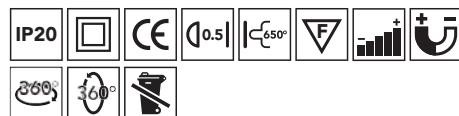

INSOLIT

c/ Cerignola 13, 08022 Barcelona
+34 932 507 640 • insolit@insolitbcn.com • insolitbcn.com

1111

Stick Box



Proyector LED orientable fabricado en aluminio mecanizado con óptica de 10° o 25° para instalación de empotrado directo con cajetín eléctrico.

Directional machined aluminum LED spotlight with 10° or 25° optic beam angle for built-in installation with an electric box.

Código / Code	1111
Acabados / Finishes	01 Blanco / White 03 Negro / Black 04 Champagne 00 RAL (Consult)
Luz / Light	27 LED 6W - 600 lm - 2700K 200/240V 50/60Hz 30 LED 6W - 600 lm - 3000K 200/240V 50/60Hz Driver suministrado / Driver supplied
Ángulo de apertura / Beam angle	10 10° 25 25°
Acabados especiales / Special finishes	30 Bronce / Bronze 31 Latón satinado / Brushed brass 33 Grafito satinado / Brushed graphite
Diseñador / Designer	Josep Ll. Xuclà
Año / Year	2020
Peso / Weight	0,28 kg
Potencia máx. / Max Power	6W
Regulación / Dimmable	TRIAC
Material	Aluminio / Aluminium
Alimentación LED / LED tension	500mA
CRI	90
Dimensiones embalaje / Box Dimensions	38x22x11mm
Instalación / Installation	Empotrado directo con cajetín eléctrico circular suministrado. <i>Built-in with an electric box (supplied).</i>

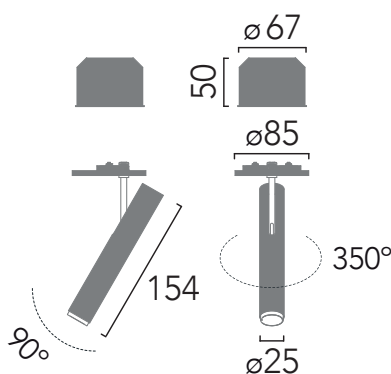

Fabricado según normativa EN60598-1 y regulaciones pertinentes. / *Manufactured according EN60598-1 normative and relevant regulations.*



Stick Box

Josep Ll. Xuclà

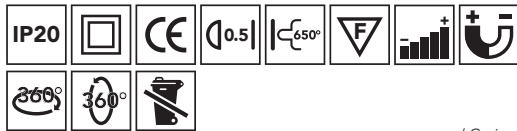
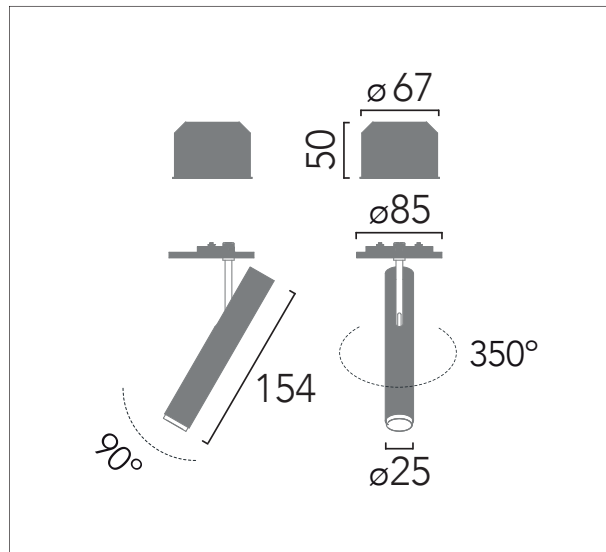

INSOLIT

c/ Cerignola, 13
08022 Barcelona
+34 932 507 640
insolit@insolibtcn.com
insolibtcn.com

Stick Box

Josep Ll. Xuclà



1111XX01

Instrucciones de montaje
Installation instructions

INSOLIT

Instalación y conexión / Installation and Connection

