

# LP

Josep Ll. Xuclà

Luminaria de pie fabricada en tubo de aluminio cortado a láser. Luz ambiente indirecta hacia la pared y luz indirecta focal hacia el techo. Dos potenciómetros integrados para el control de la luz independiente de las dos encendidas.

*Floor luminaire made of laser cut aluminum tube. Indirect ambient light towards the wall and indirect focal light towards the ceiling. Two integrated dimmers for independent light control of the two lights.*



LP 1130

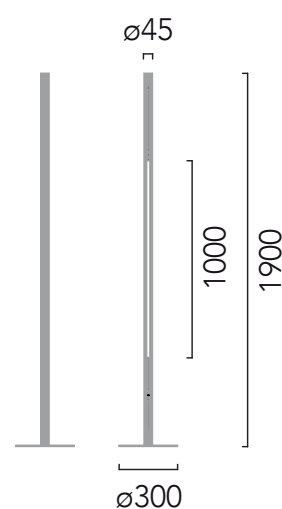

#### Luz / light

LED 25W 2500 lm 2700K ( Up )  
LED 25W 2500 lm 2700K ( Wall )  
220/240V 50/60Hz

#### Acabados / Finishes

Blanco / White  
Negro / Black  
Custom RAL  
Bronce / Bronze  
Latón satinado / Brushed brass  
Níquel satinado / Brushed nickel

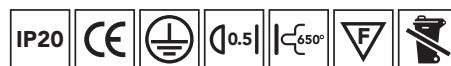



Luminaria de pie fabricada en tubo de aluminio cortado a láser. Luz ambiente indirecta hacia la pared y luz indirecta focal hacia el techo. Dos potenciómetros integrados para el control de la luz independiente de las dos encendidas.

Floor luminaire made of laser cut aluminum tube. Indirect ambient light towards the wall and indirect focal light towards the ceiling. Two integrated dimmers for independent light control of the two lights.

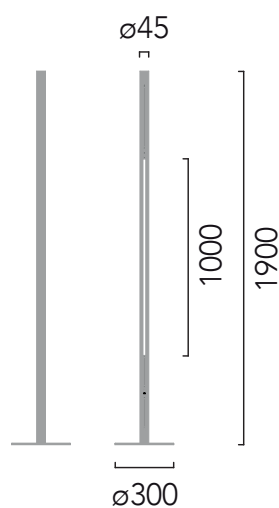

<b>Código / Code</b>	<b>1130</b>
<b>Acabados / Finishes</b>	<b>01</b> Blanco / White <b>03</b> Negro / Black <b>00</b> RAL (Consult)
<b>Luz / Light</b>	<b>27</b> LED 25W 2500 lm 2700K ( Up ) LED 25W 2500 lm 2700K ( Wall ) 220/240V 50/60Hz
<b>Acabados especiales / Special finishes</b>	<b>30</b> Bronce / Bronze <b>31</b> Latón satinado / Brushed brass <b>32</b> Níquel satinado / Brushed nickel
<b>Diseñador / Designer</b>	Josep Ll. Xuclà
<b>Año / Year</b>	2020
<b>Peso / Weight</b>	4,3 kg
<b>Potencia máx. / Max Power</b>	25W
<b>Material</b>	Aluminio / Aluminium
<b>Alimentación LED / LED tension</b>	700mA
<b>CRI</b>	90
<b>Dimensiones embalaje / Box Dimensions</b>	200x50x50cm / 31x31x2cm
<b>Instalación / Installation</b>	

Sin instalación, enchufado directo.

No installation, direct plug-in.

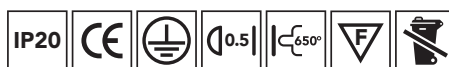

Fabricado según normativa EN60598-1 y regulaciones pertinentes. / Manufactured according EN60598-1 normative and relevant regulations.



# LP

Josep Ll. Xuclà

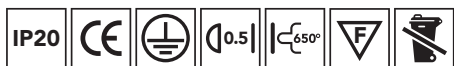
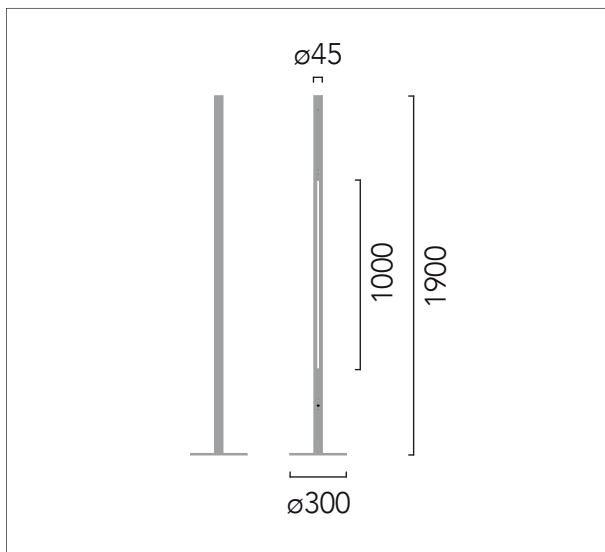

# INSOLIT

c/ Cerignola, 13  
08022 Barcelona  
+34 932 507 640  
insolit@insolitbcn.com  
insolitbcn.com

# LP

Josep Ll. Xuclà



## 1130XX30

Instrucciones de montaje

Installation instructions

# INSOLIT

### Instalación y conexión / Installation and Connection

